

VERTICAL CURB

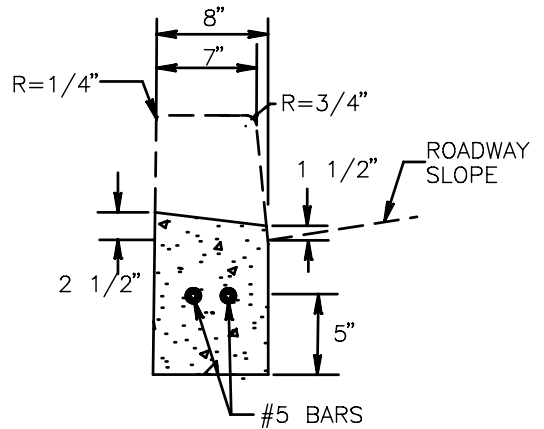

DEPRESSED CURB

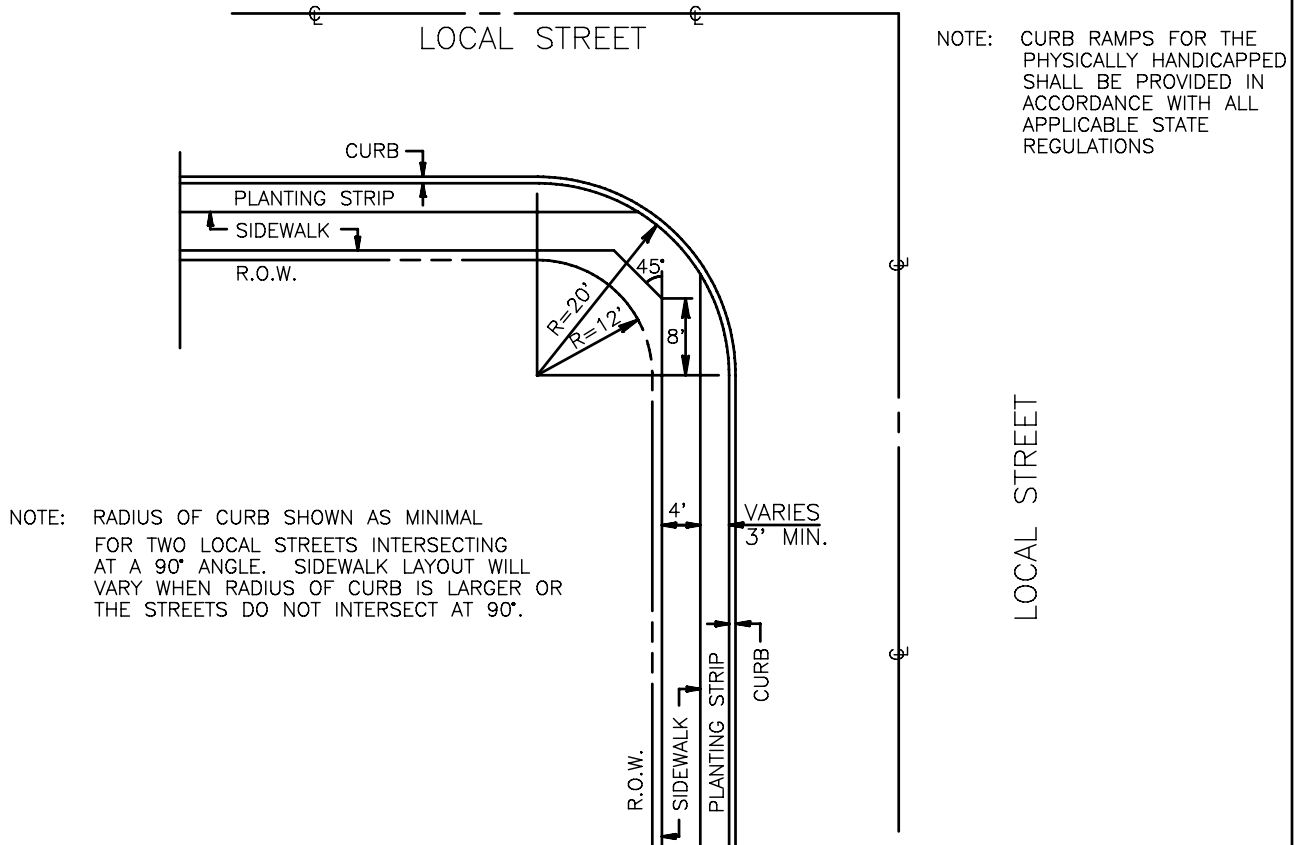

APPENDIX A-3
SIDEWALK & CURB LAYOUT /
STANDARD STRAIGHT CURB DETAIL

NOT TO SCALE